

DRESTER 10500CS

Unique Solvent Recycler with superior recovery rates and built-in pump station

- ◆ The Drester 10500CS can be used with any Gun Cleaner on the market
- ◆ ETL listed for US and Canada in accordance with UL 2208
- ◆ Unique water-cooled condenser enabling unparalleled recovery rates
- ◆ A built in pump station minimizes the need to manhandle solvent. Easy fill-up and discharge of solvent.
- ◆ State of the art self setting electronics. All vital parameters are continuously monitored for safe and easy use.
- ◆ Monitoring of solvent level. No risk of starting the recycler if there is not enough room in the collecting drum.



DRESTER

when results count

Technical Data

Electrical protection	Intrinsic protection & explosion proof
Fuse	10 A Delayed action
Power supply	200-240 Volt AC, 50/60 Hz
Current	Max 9 A
Heater	1.8 kW
Total power	1.9 kW
Power cable length	25 feet
Capacity	5.3 gallons / 20 liters
Operating temperature	41 °F to 390 °F / 50 °C to 199 °C
Safety thermostat	392 °F / 200 °C
Max ambient temperature	104° F / 40 °C
Air supply (for pumps)	75 psi at 3 cfm / 5 bar at 85 liters/min
Pump capacity	2.6 gallons per min / 10 liters per min
Dimensions	Operating height (to boiler lid)
	40.5" / 1.030 mm
	Max height (to condenser lid)
	61" / 1.545 mm
	Width: 19" / 480 mm
	Depth: 28" / 708 mm
Weight: 187 lbs / 85 kg dry	
264 lbs / 120 kg (topped up with condenser water and ready to use)	



The unique Drester diaphragm pump specifically designed to handle solvent, comes with a 4-year warranty.

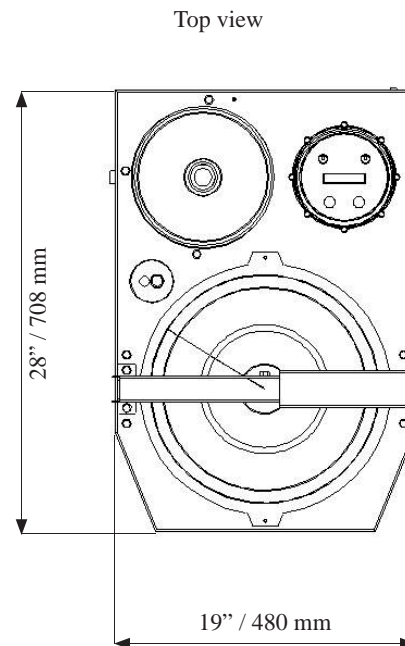
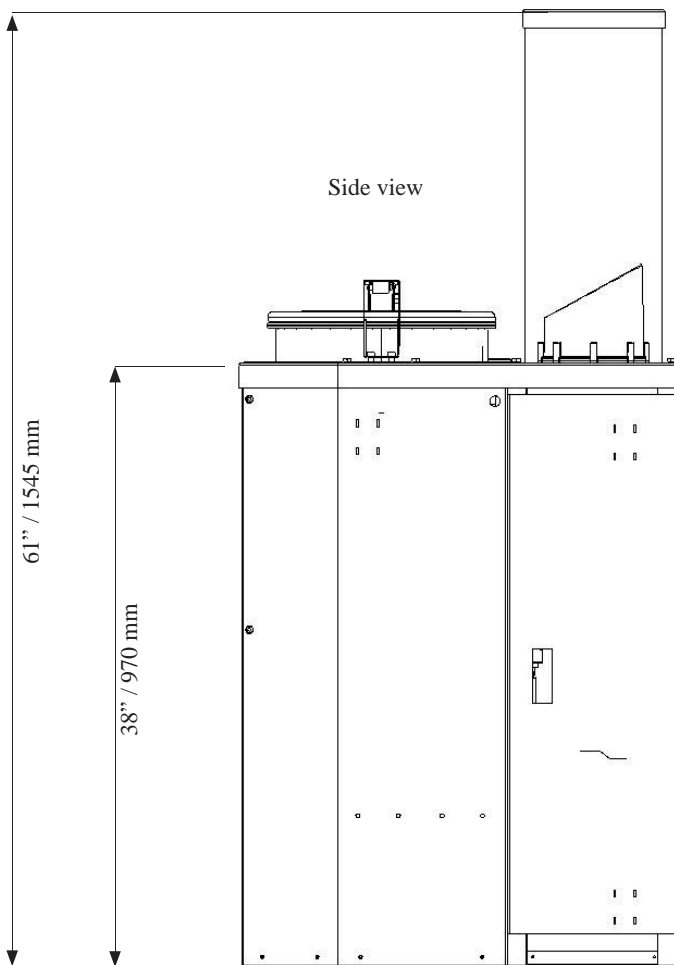

Purpose of the machine: The DRESTER 10500CS is intended to recycle thinner-based solvents normally used in a body shop (ref. user's manual)